

---

# Deformation Monitoring of a Parabolic Roof Structure using TLS

Erdélyi, J., Kopáček, A., Ilkovičová, L., Lipták, I. and Kajánek, P.

Slovak University of Technology, Faculty of Civil Engineering, Radlinskeho 11, 813 68 Bratislava, Slovakia, Web site: [www.svf.stuba.sk](http://www.svf.stuba.sk), E-mail: [jan.erdelyi@stuba.sk](mailto:jan.erdelyi@stuba.sk)

## Abstract

The paper deals with the geodetic monitoring of a parabolic shaped reinforced concrete roof structure in the chemical company Duslo, Ltd. in Šaľa (Slovak Republic). The monitored structure is a part of the roof of a warehouse used for the storage of fertilizer. The atmospheric conditions and the operation load caused deformation of the construction. For measurement was used the technology of terrestrial laser scanning. The displacements of the observed parts of the construction were calculated using planar surfaces by the procedure of Singular Value Decomposition of matrixes. The procedure of initial and 2 epochal measurements of deformations, the procedure of the data processing, and the results of the deformation monitoring are described.

**Key words:** Deformation Monitoring, Terrestrial Laser Scanning, Reinforced-concrete construction, Singular Value Decomposition

## 1 INTRODUCTION

The weather conditions and the operation load are causing changes in the spatial position and in the shape of engineering constructions, which affects their static and dynamic function and reliability. Because these facts, geodetic measurements are integral parts of engineering structures diagnosis.

This paper presents the geodetic monitoring of a parabolic shaped reinforced concrete roof construction of a fertilizer warehouse in the Duslo, Ltd., Šaľa, which is the largest chemical company in the Slovak republic. The operation load and the weather conditions caused shift between the blocks of the roof during the decades of operation. The measurements were done in 3 epochs during 2 months. The stability of the foundation strips of the construction was monitored by precise levelling. The deformation of the roof construction was measured using terrestrial laser scanning (TLS).

The advantage of TLS over conventional surveying methods is the efficiency of spatial data acquisition. TLS allows contactless determining the spatial coordinates of points lying on the surface on the measured object. The scan rate of current scanners (up to 1 million of points/s) allows significant reduction of time, necessary for the measurement; respectively increase the quantity of obtained information about the measured object. To increase the accuracy of results, chosen parts of the monitored construction can be approximated by single geometric entities using regression. In this case the position of measured point is calculated from tens or hundreds of scanned points (Vosselman et al., 2010).

## 2 CHARACTERISTICS OF THE MEASURED OBJECT

The measured object is used for storage of fertilizer in the chemical company Duslo, Ltd., Šaľa. It consists of a reinforced concrete construction with dimensions 30 m x 170 m and with height 14 m. On the roof in the middle part of the construction is situated a conveyor along the whole warehouse. The warehouse is founded on foundation strips (with dimensions 3.7 m x 172.0 m x 1.5 m) and is divided into 5 blocks.



Figure 1 The construction of the warehouse

The roof consists of a parabolic shaped reinforced concrete construction with parabolic transverse beams (with axial distance 4.8 m). The warehouse was built in year 1960. The operation load of the conveyor, and the weather conditions caused deformation of the roof construction during the decades of operation. The mentioned reasons caused a shift approximately 150 mm between the 1<sup>st</sup> and the 2<sup>nd</sup> block, which is visible at the dilatation.

The aim of the measurements was the geodetic monitoring of the parts of the roof construction near the dilatation joints, and the determination of the rate of changes.

## 3 DEFORMATION MONITORING

Considering the unclear cause of deformations, the monitoring was designed to be able not only to quantify the movements of the mentioned parts of the roof structure, but even the eventual motions of foundations. The measurements were done in 3 epochs during 2 months, on October 7<sup>th</sup>, October 21<sup>st</sup> and December 2<sup>nd</sup> 2013. The aim of the monitoring was to determine the rate of the displacements, and to determine their influence to the secure operation. The deformations of the roof construction were monitored using terrestrial laser scanning, and the behavior of the foundations was measured by precise levelling.

### 3.1 PRECISE LEVELLING

The monitoring of the foundation strips was performed in 3 measurement epochs (mentioned above) using precise levelling. The height of 8 measured points (N1.1-N2.4) was determined relative to the height of 3 control points (VB1-VB3) in a local height system (Fig. 2). The control points are situated near the monitored object, in the footings of the pylons of a pipeline nearby the warehouse. These are stabilized by ground benchmarks. The stability of

the reference net was determined comparing the height differences between the points in each epoch.

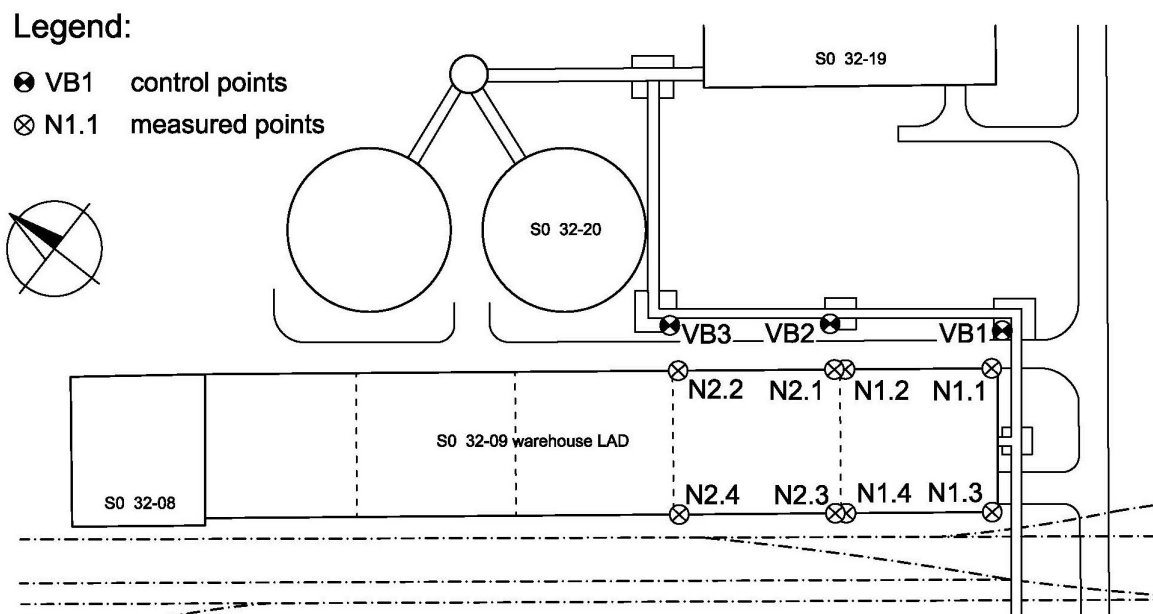

Figure 2 Position of measured and control points – precise levelling

The measured points are situated on the beginning and end of 1<sup>st</sup> and 2<sup>nd</sup> block on the both sides of the warehouse. The points are stabilized by wall benchmarks in the bottom part of the parabolic transverse beams. The vertical displacements of these points were determined as the difference between the heights of these points in each epoch.

Table 1 Vertical Displacements – Precise Levelling

Point No.	Vertical displacements of observed points considering to initial measurement (October 7 <sup>th</sup> 2013)						
	Height of points	October 21 <sup>th</sup> 2013			December 2 <sup>nd</sup> 2013		
	H [mm]	h [mm]	$\sigma_h$ [mm]	Decision	h [mm]	$\sigma_h$ [mm]	Decision
N1.1	100.2167	0.0	0.28	no shift	+0.7	0.28	5%
N1.2	100.0306	-0.3	0.28	5% - 30%	-0.6	0.28	5% - 30%
N1.3	99.7724	+0.1	0.28	no shift	----	--	----
N1.4	100.2479	+0.1	0.28	no shift	-0.4	0.28	5% - 30%
N2.1	99.9793	-0.1	0.28	no shift	+0.6	0.28	5% - 30%
N2.2	100.0296	-0.6	0.28	5% - 30%	-0.2	0.28	no shift
N2.3	100.2393	+0.1	0.28	no shift	-0.3	0.28	5% - 30%
N2.4	99.9995	-0.5	0.28	5% - 30%	0.0	0.28	no shift

The statistical significance of the displacements was determined on the basis of the statistical analysis using interval estimates. The measurement did not shown any displacements on most of the observed points; respectively, the risk of the decision is 5% - 30%. Due to the results of precise levelling, it can be assumed that the foundation strips of the structure are stable, or the movements are slow without influence to the security.

### 3.2 TERRESTRIAL LASER SCANNING

The monitoring of the roof structure was performed using TLS Leica ScanStation2. The bottom side of the roof was scanned from a single position of the scanner. Scanned was a 1 m wide strip on the both sides of the dilatation (Fig. 3). It was not possible to scan strip along the whole dilatation, because the fertilizer was not removed from the left side of the mentioned part of the structure. The scanner was positioned in each epoch approximately in the same position to ensure the same conditions of the measurements (distance from the scanner, angle of incidence of the measuring signal).

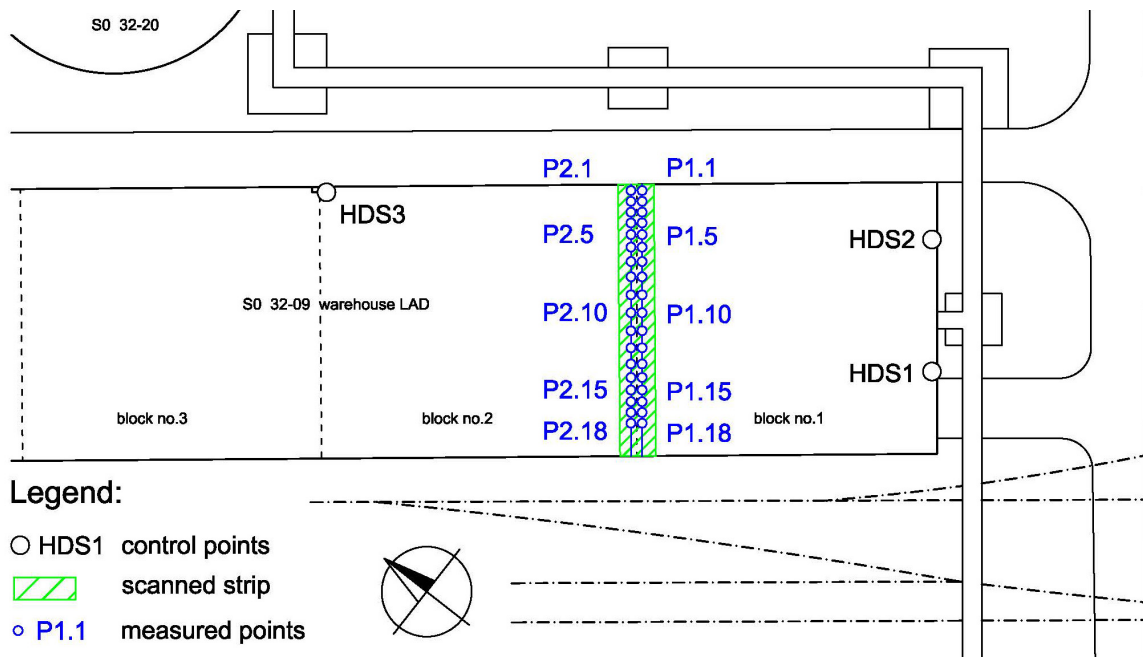

Figure 3 Position of measured and control points – terrestrial laser scanning

The reference network consists of three control points stabilized on the pillars of the warehouse frame by metallic fasteners (it was possible due to the stability of the foundations). All of the control points were signalized by the Leica HDS targets. To improve the efficiency of the measurements, a simple script was defined before scanning in each epoch. This script defines a separate field of scanning for different parts of the construction, the scan resolution in each field, and the target acquisition. The minimal point density on the surface of the roof was 10 mm x 10 mm.

The data obtained by the TLS were transformed to a local coordinate system. The accuracy of the transformation was calculated from the differences between the common identical points after the transformation. The main task of the data processing was modelling the position of the measured points by small planar surfaces. These are positioned on the bottom side of the roof every 2 m on the both sides of the dilatation (Fig. 3).

The vertical displacements of the measured points were determined as the difference between the heights of these points in each epoch. The height of the points was calculated using orthogonal regression. The vertical displacements were recalculated to orthogonal displacements along the normal vector to the surface in each part of the structure. During the data processing of the initial measurement, square fences of 0.1 m x 0.1 m were defined on the bottom side of the roof. These fences approximately define the same set of points in each epoch.

Orthogonal regression is calculated from the general equation of a plane by applying Singular Value Decomposition:

$$\mathbf{A} = \mathbf{U}\mathbf{\Sigma}\mathbf{V}^T \quad (1)$$

where  $\mathbf{A}$  is the design matrix, with dimensions  $n \times 3$ , and  $n$  is the number of points used for the calculation. The design matrix contains the coordinates of the point cloud reduced to a centroid. The column vectors of  $\mathbf{U}^{n \times n}$  are normalized eigenvectors of matrix  $\mathbf{A}\mathbf{A}^T$ . The column vectors of  $\mathbf{V}^{3 \times 3}$  are normalized eigenvectors of  $\mathbf{A}^T\mathbf{A}$ . The matrix  $\mathbf{\Sigma}^{n \times 3}$  contains eigenvalues on the diagonals. Then the normal vector of regression plane is the column vector of  $\mathbf{V}$  corresponding to the smallest eigenvalue from  $\mathbf{\Sigma}$  (Lacko, 2008).

The mean errors of the displacements were obtained using the law of propagation of uncertainty, from the mean error of the transformation and the mean error of the regression planes, which were calculated from the orthogonal distance of points from these planes. The statistical significance of the displacements was determined on the basis of the statistical analysis using interval estimates (Kopáček et al., 2013). Table 2 shows the displacements (vertical and orthogonal) of the selected points observed.

Table 2 Displacements – Terrestrial Laser Scanning

Point No.	Displacements of observed points considering to initial measurement (October 7 <sup>th</sup> 2013)									
	October 21 <sup>th</sup> 2013					December 2 <sup>nd</sup> 2013				
	$\Delta z$ [mm]	$\sigma$ [mm]	Decision	Orth. disp. [mm]	Decision	$\Delta z$ [mm]	$\sigma$ [mm]	Decision	Orth. disp. [mm]	Decision
P1.1	0	1.7	no shift	0	no shift	0	1.4	no shift	0	no shift
P1.2	0	2.2	no shift	0	no shift	-3	1.6	5%- 30%	-1	no shift
P1.3	-2	2.1	no shift	-1	no shift	1	1.7	no shift	1	no shift
P1.4	-2	1.8	no shift	-1	no shift	1	1.5	no shift	1	no shift
P1.5	-3	1.6	5%-30%	-2	5%- 30%	-1	1.5	no shift	-1	no shift
P1.6	-4	1.4	5%	-2	5%- 30%	-2	1.3	5%- 30%	-2	no shift
P1.7	-4	1.4	5%	-3	5%- 30%	-4	1.1	5%	-3	5%- 30%
P1.8	-3	1.4	5%	-2	5%- 30%	-5	1.3	5%	-4	5%
P1.9	-3	1.7	5%-30%	-3	5%- 30%	-5	1.3	5%	-5	5%
P1.10	-1	2.2	no shift	-1	no shift	-3	1.9	5%- 30%	-3	5%- 30%
P1.11	0	2.2	no shift	0	no shift	-4	1.6	5%	-4	5%
P1.12	0	2.1	no shift	0	no shift	-4	1.6	5%	-3	5%- 30%
P1.13	2	2.2	no shift	2	no shift	-1	1.7	no shift	-1	no shift
P1.14	2	2.1	no shift	2	no shift	0	1.9	no shift	0	no shift
P1.15	3	2.1	5%-30%	2	no shift	2	1.9	no shift	1	no shift
P1.16	4	2.0	5%-30%	2	no shift	3	1.6	5%- 30%	2	5%- 30%
P1.17	2	1.8	no shift	1	no shift	0	1.5	no shift	0	no shift
P1.18	0	1.9	no shift	0	no shift	-1	1.8	no shift	0	no shift

The measurement did not show any displacements on most of the observed points; respectively, the movements are slow with the risk of the decision 5% - 30%. The Fig. 4 shows the graphical representation of the displacements of the selected points between the initial measurement (October 7<sup>th</sup>) and the 2<sup>nd</sup> measurement epoch (October 21<sup>st</sup>).

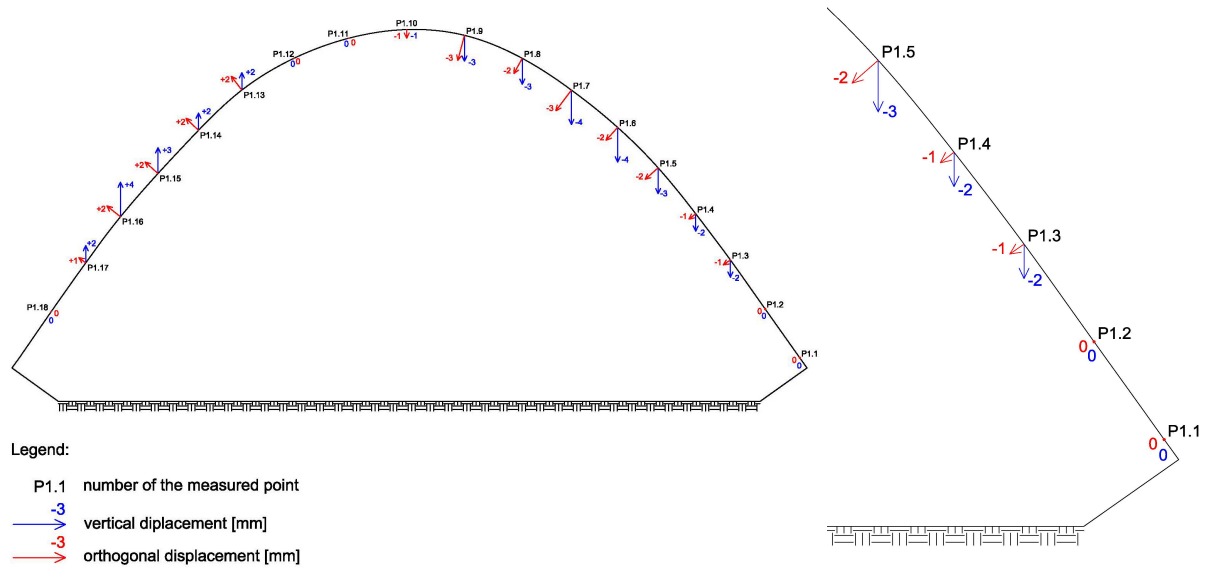

Figure 4 Displacements in the 1<sup>st</sup> control epoch (right), and the detail of vertical and orthogonal displacements (left)

## 4 CONCLUSION

The aim of the monitoring described in this paper was to determine the rate of the displacements, and to determine their influence to the secure operation of the warehouse. The results did not show significant displacement of the monitored part of the warehouse construction (see Table 1 and Table 2). Due to these facts the measurements planned for the future were cancelled. Mechanical measuring equipment was mounted on the mentioned part of the structure. The eventual deformation will be monitored visually, by the operating staff of the warehouse.

## REFERENCES

- KOPAČIK, A. et al. 2013. Deformation Monitoring of Bridge Structures Using TLS. In 2<sup>nd</sup> Joint International Symposium on Deformation Monitoring [USB]. Nottingham: University of Nottingham, 2013, 8 p.
- LACKO, V. 2008. Singular Value Decomposition and Difficulties of Software Implementation of Golub Algorithm and its Determination: Student science conference. Bratislava: Comenius University in Bratislava, 2008. 69 p.
- VOSELMAN, G. – MAAS, H. G. 2010. Airborn and Terrestrial Laser Scanning. Dunbeath: Whittles Publishing, 2010. 318 p. ISBN 978-1904445-87-6.