

3D modely konštrukcie

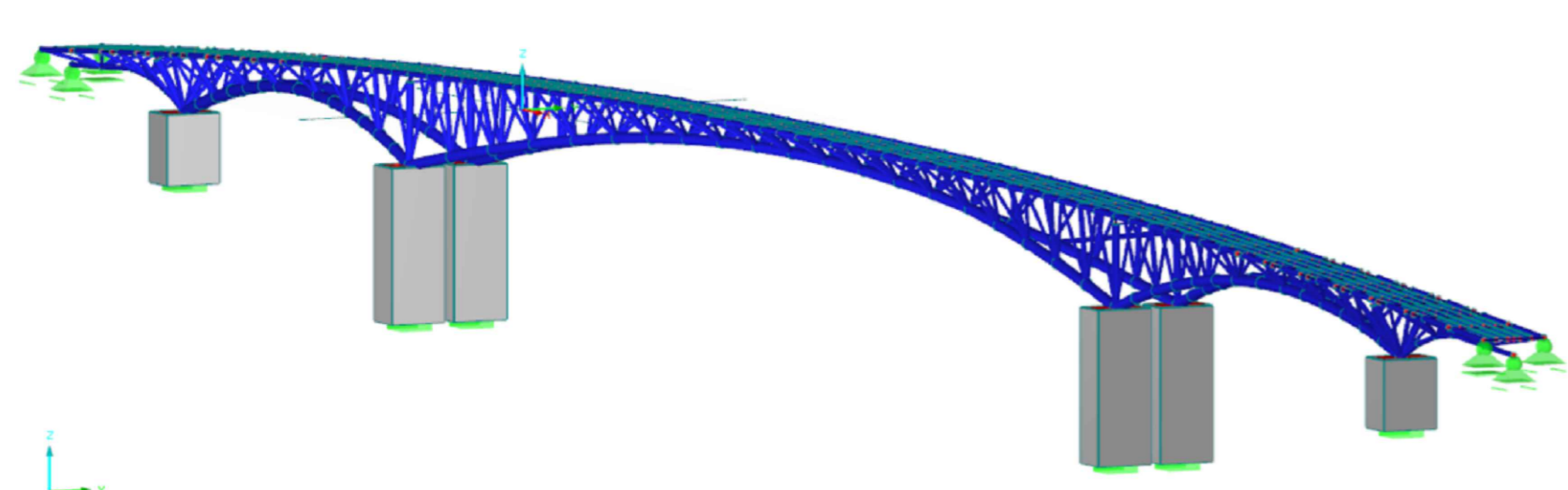

1. variant - oblúková priehradová lávka

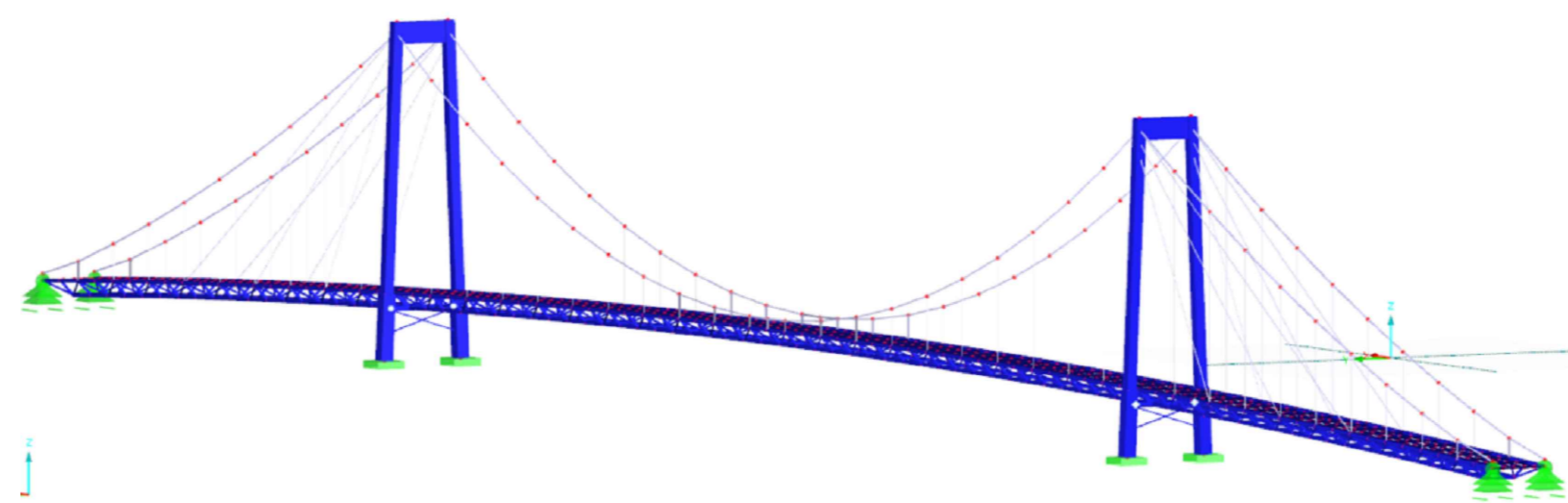

2. variant - visutá lávka

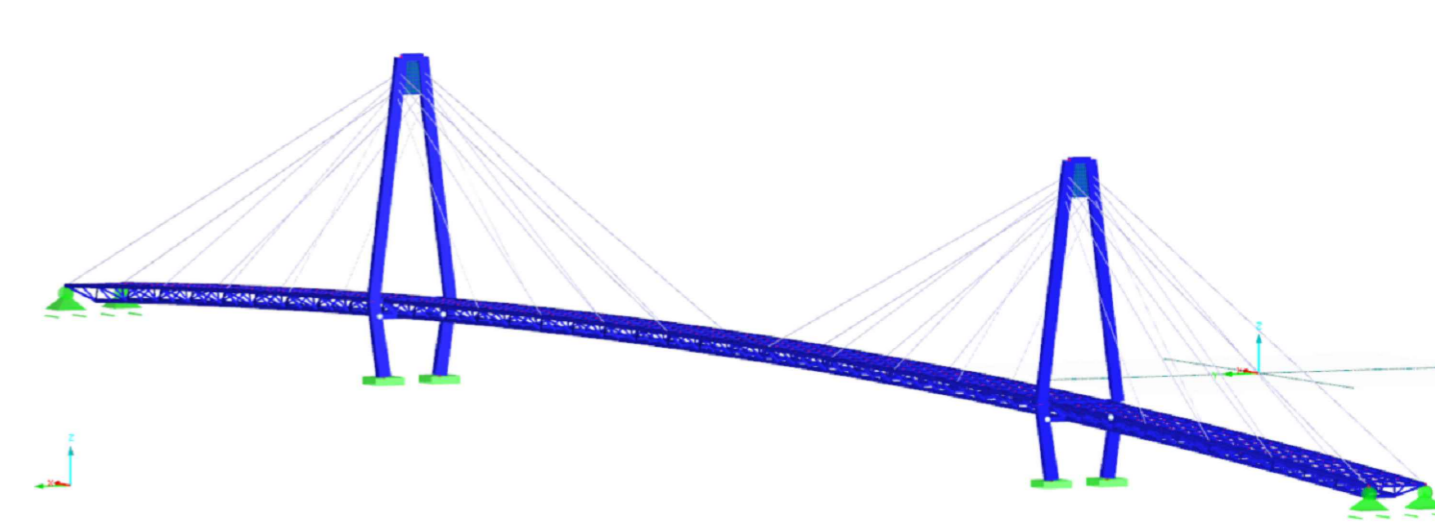

3. variant - zavesená lávka

Situácia umiestnenia objektu

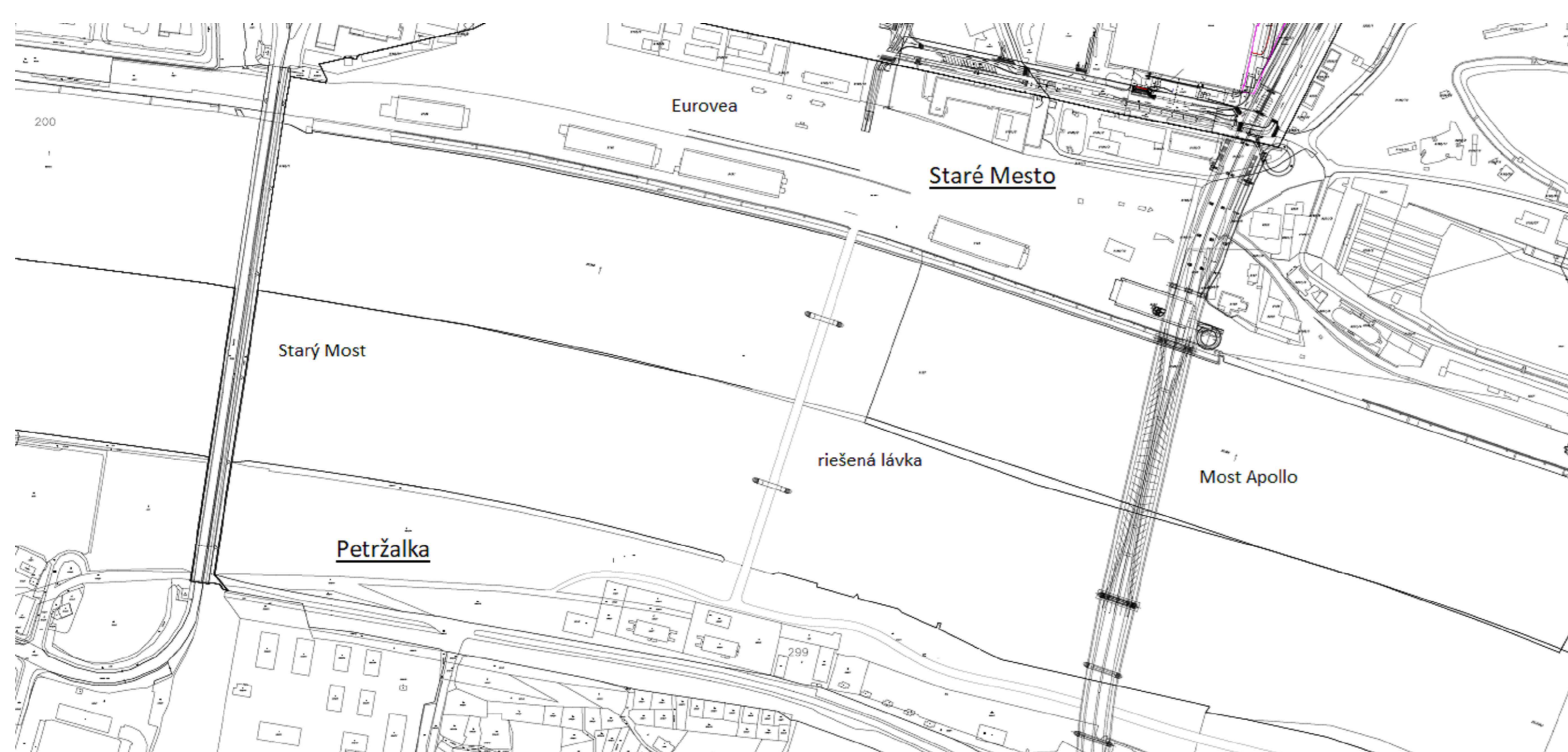

Celková situácia



Schéma plavebného gabaritu a dĺžky konštrukcie



Výškový rozdiel v pozdĺžnom smere

Priehyb od plného zaťaženia chodcami a teplotou

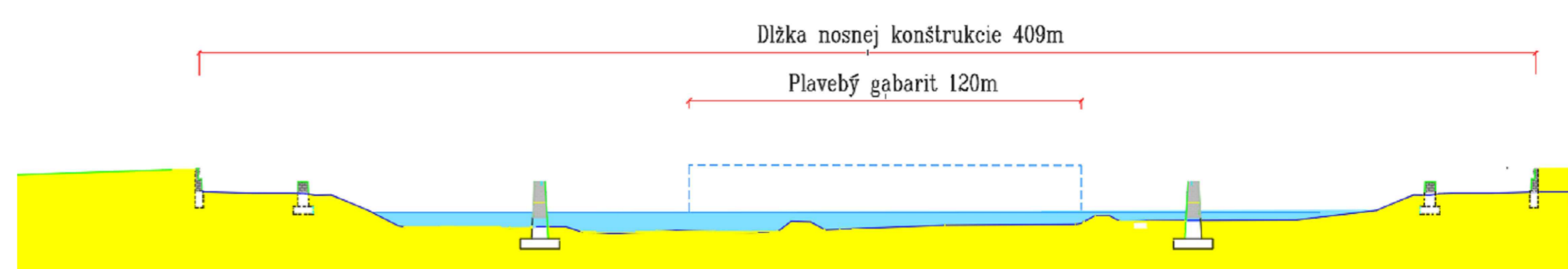
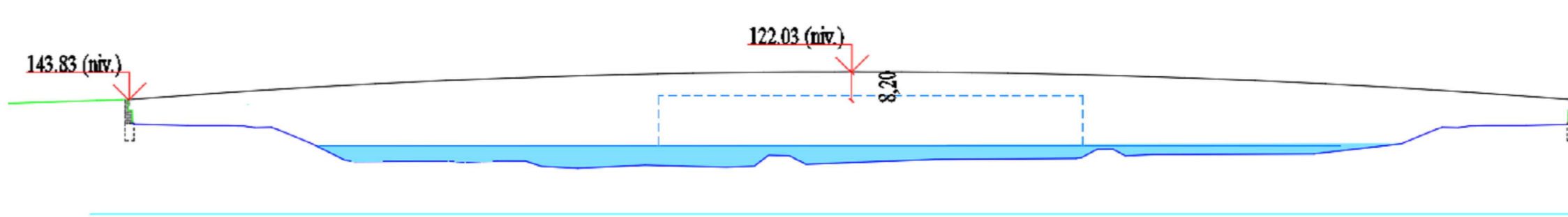
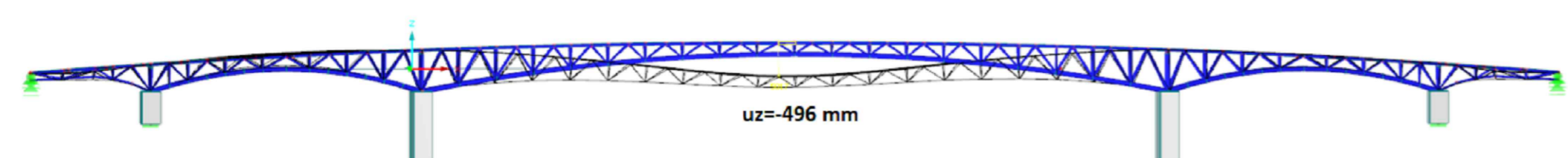

1. variant - častá kombinácia

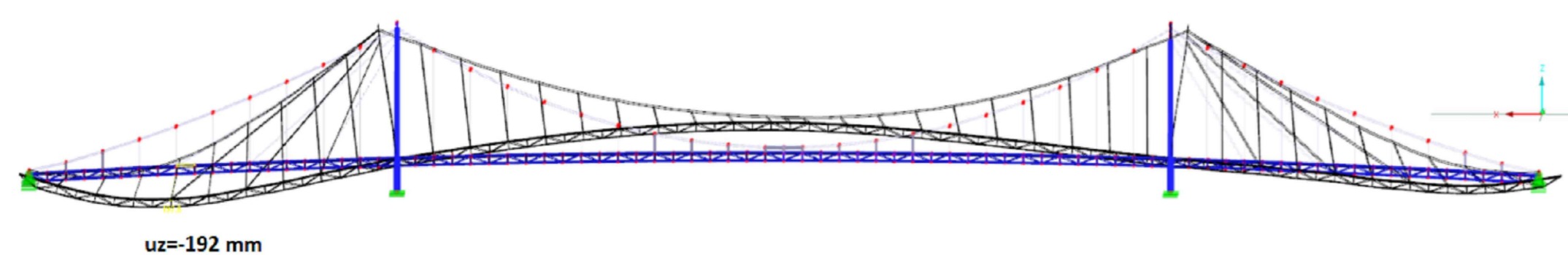

2. variant - častá kombinácia

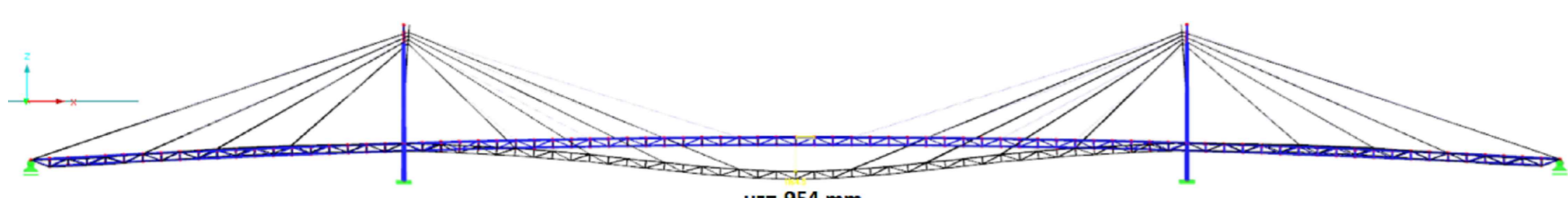

3. variant - častá kombinácia

Vplyvová čiara

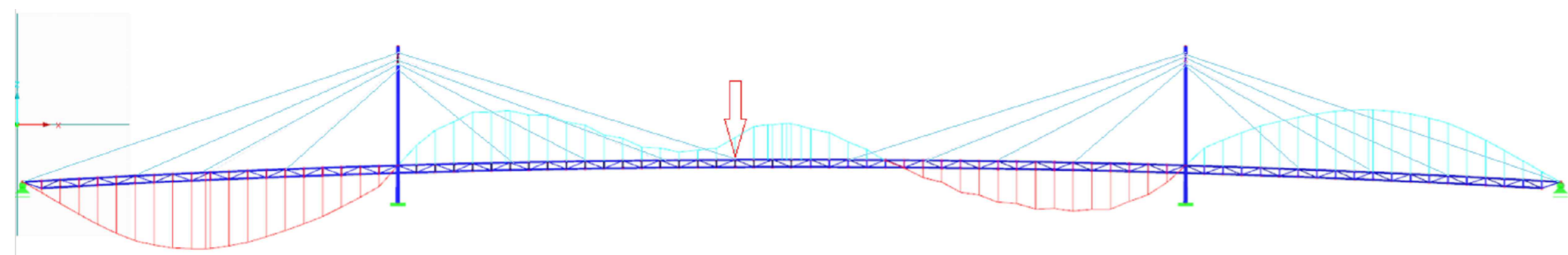

Vplyvová čiara pre horné lano

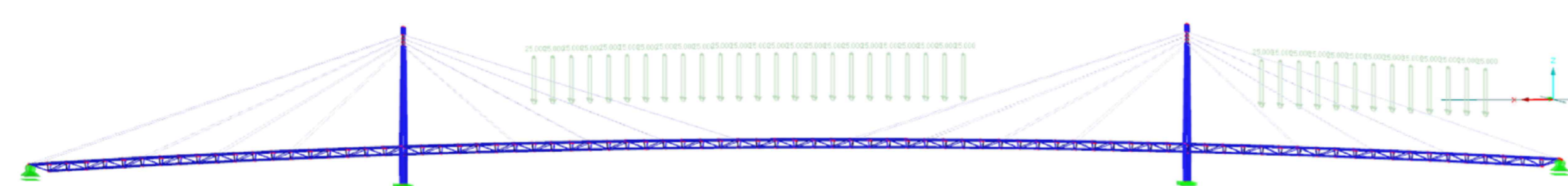

Zaťažovací stav vygenerovaný na základe vplyvovej čiary

Vybrané detaily

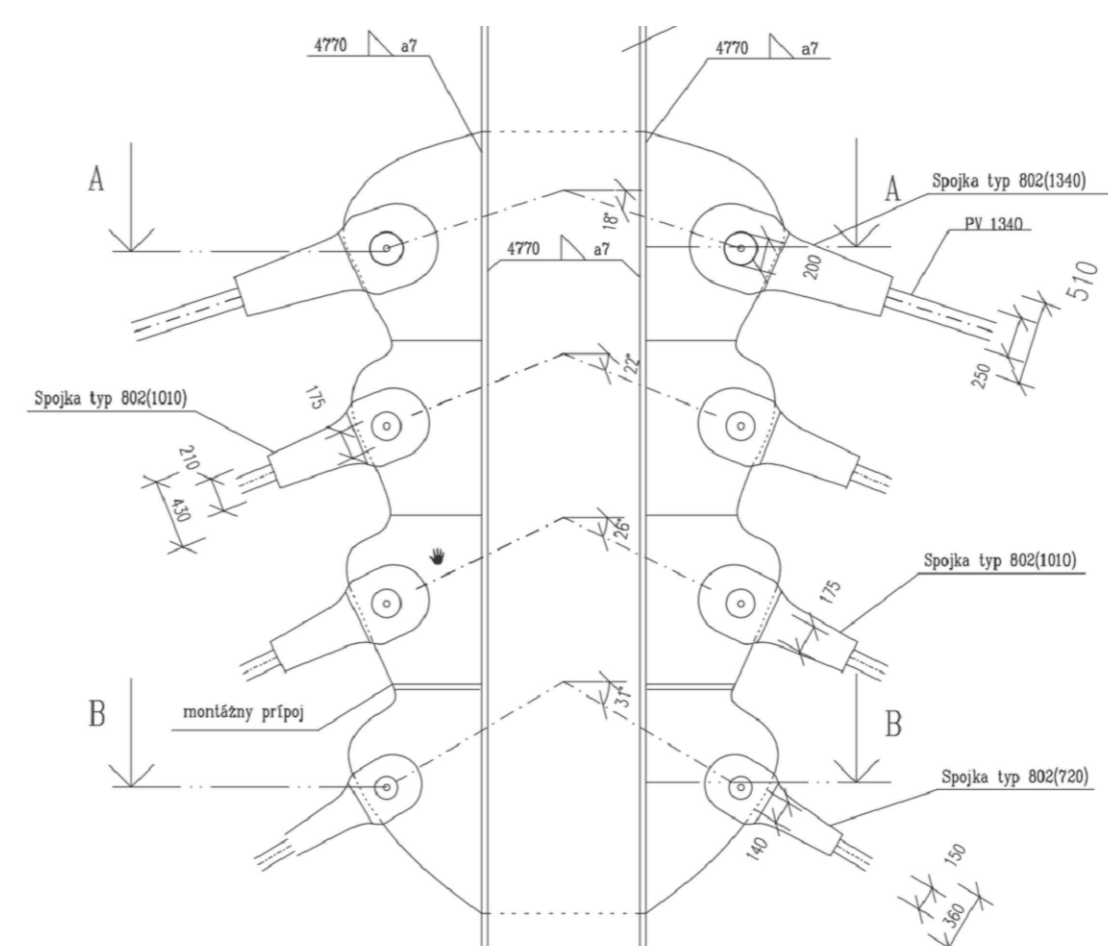

Detail ukotvenie lán k pylónu

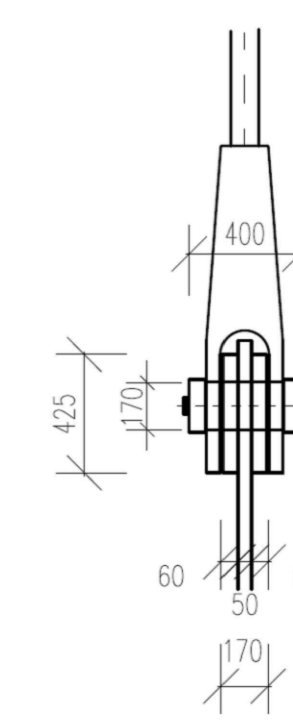

Detail spojky lana

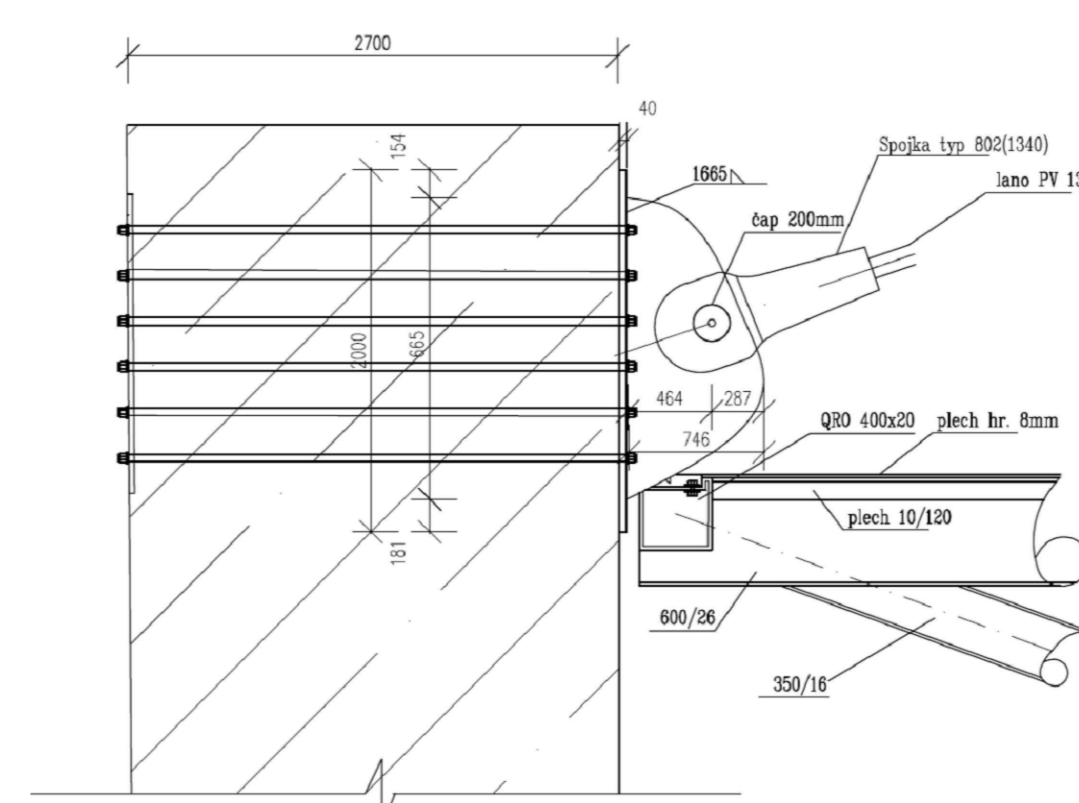

Detail ukotvenia lana k základu a uloženia na posúvne závery

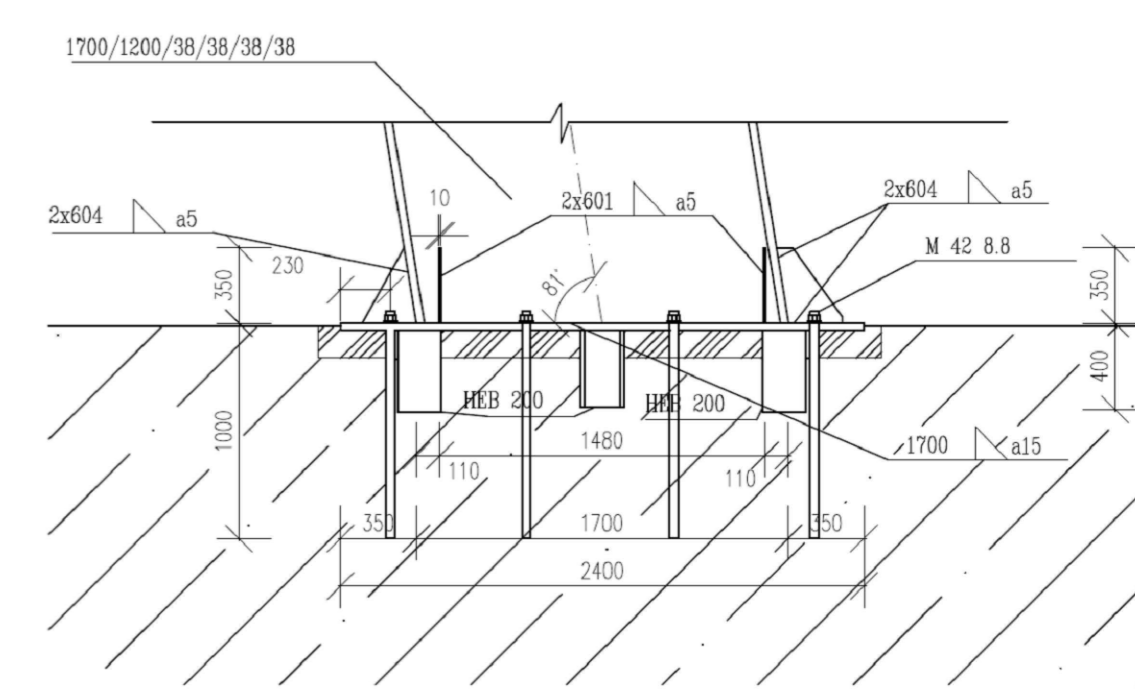

Detail ukotvenia pylóna

Zaťaženie vetrom



Schéma zaťaženia vetrom pre 1. variant



Schéma zaťaženia vetrom pre 2. a 3. variant

Stabilita rámu

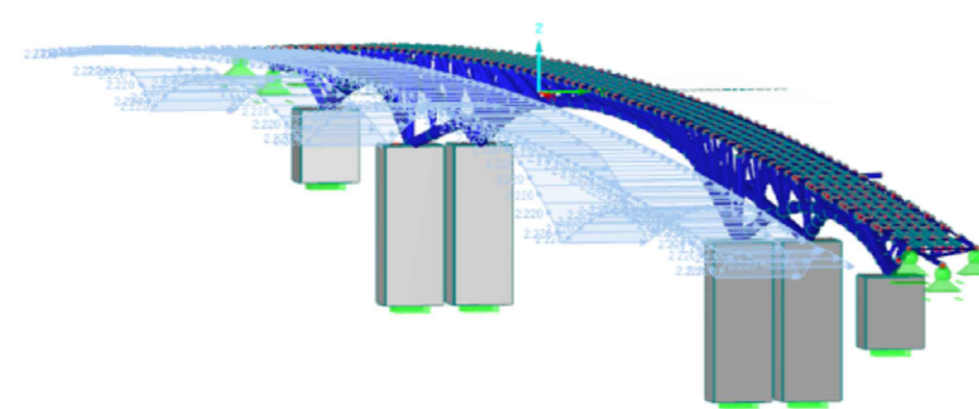
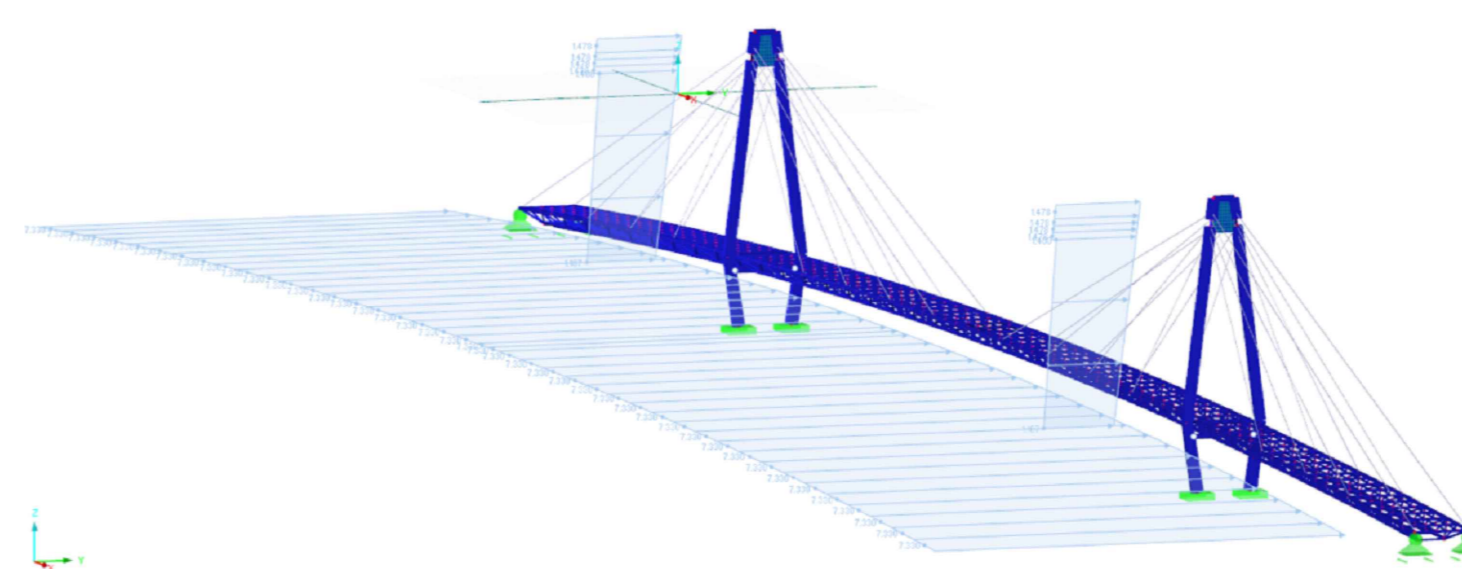
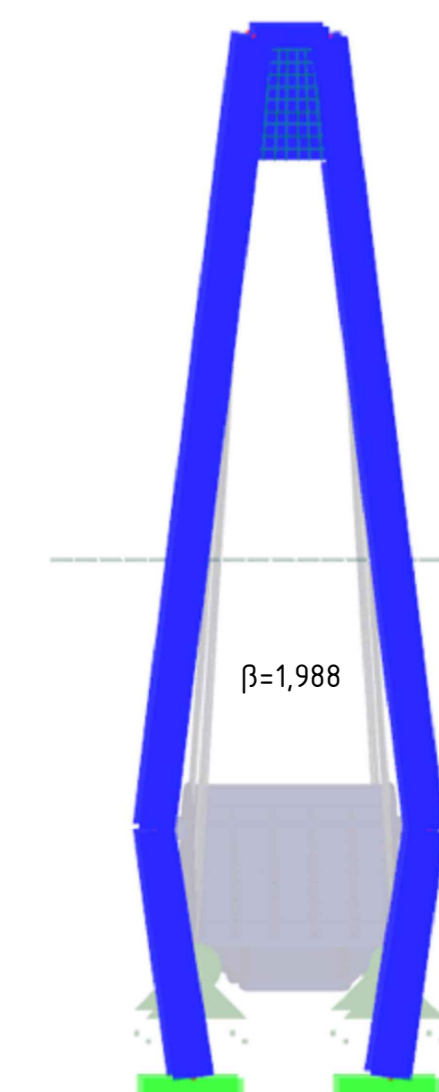

Schéma pre výpočet stability rámu